

Project ASD Girder Design Example				Job Ref. Design Examples	
Section Composite Beam Design				Sheet no./rev. 1	
Calc. by JRE	Date 4/7/2009	Chk'd by AJR	Date 4/8/2009	App'd by JRE	Date 4/9/2009

FASTRAK Composite Beam Design

ASD Girder Design Example Calculation

FASTRAK Composite Beam Design is a design tool for composite and non-composite beams with flexible loading options, design criteria, and stud optimization and placement. This powerful tool is available **FREE** in the US and can be downloaded from http://www.cscworld.com/fastrak/us/composite_download.html

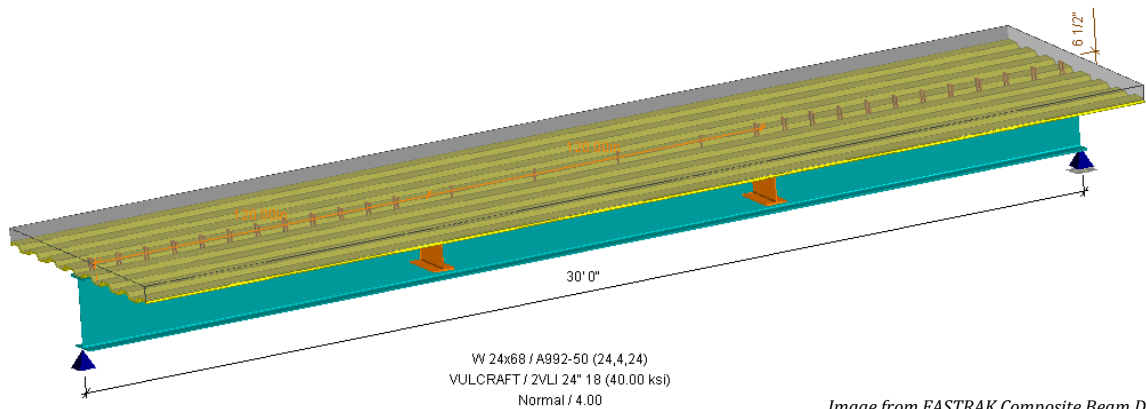
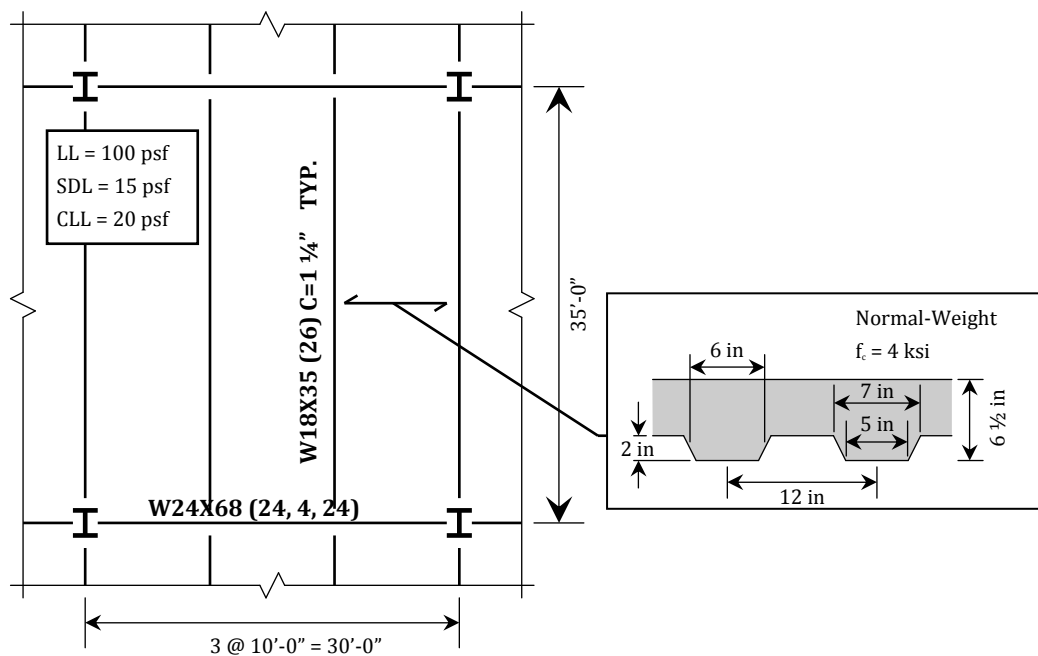

Image from FASTRAK Composite Beam Design

The purpose of this document is to help you quickly build confidence when using FASTRAK. This document shows the long-hand engineering for the ASD Girder Design tutorial example provided in the installation. This same example is used in the written and video tutorials accompanying FASTRAK Composite Beam (available at http://www.cscworld.com/fastrak/us/composite_resources.html).

This document was produced using the TEDDS calculation software.

Design Details





CSC Inc
500 N Michigan Ave
Chicago, IL 60611

Project				Job Ref.	
ASD Girder Design Example				Design Examples	
Section				Sheet no./rev.	
Composite Beam Design				2	
Calc. by	Date	Chk'd by	Date	App'd by	Date
JRE	4/7/2009	AJR	4/8/2009	JRE	4/9/2009

BASIC DATA

Typical Interior Girder: W24X68 (24, 4, 24)

Beam Length (Girder Spacing)	$L_{bm} = 35 \text{ ft and } S_{gr} = L_{bm}$
Beam Spacing	$S_{bm} = 10 \text{ ft}$
Beam Size	W 18x35
Girder Length	$L_{gr} = 30 \text{ ft}$
Girder Size	W 24x68
Steel yield strength	$F_y = 50 \text{ ksi}$
Steel Modulus of elasticity	$E_s = 29000 \text{ ksi}$
Beam weight	$Weight_{BM} = 35.0 \text{ plf}$
Girder weight	$Weight_{GR} = 68.0 \text{ plf}$

Applied Floor Loads

Live Load	$F_{LL} = 100 \text{ psf - Unreduced}$
Long-term portion	$\rho_{LL_{lt}} = 33.0\%$
Long-term distributed live load	$F_{LL_{lt}} = \rho_{LL_{lt}} \times F_{LL} = 33.0 \text{ psf}$
Short-term distributed live load	$F_{LL_{st}} = (1 - \rho_{LL_{lt}}) \times F_{LL} = 67.0 \text{ psf}$
Superimposed Dead Load	$F_{SDL} = 15 \text{ psf}$
Construction Live Load	$F_{CLL} = 20 \text{ psf}$

Concrete Slab and Metal Deck

Metal Deck spans parallel to the girder.

Metal Deck Height	$h_r = 2 \text{ in}$
Average width of concrete rib	$w_r = 6 \text{ in}$
Concrete rib spacing	$s_r = 12 \text{ in}$
Width at top of concrete rib	$w_{rt} = 7 \text{ in}$
Width at bottom of concrete rib	$w_{rb} = 5 \text{ in}$
Metal Deck weight	$F_{md} = 2.61 \text{ psf}$
Topping (above metal deck)	$t_c = 4.5 \text{ in}$
Concrete compressive strength	$f_c = 4000 \text{ psi}$
Wet concrete density	$w_{c,wet} = 150 \text{ lb/ft}^3$
Dry concrete density	$w_{c,dry} = 145 \text{ lb/ft}^3$
Short-term concrete modulus of elasticity	$E_{c,st} = w_{c,dry}^{1.5} \times \sqrt{f_c} = 3492 \text{ ksi}$
Long-term to short-term Modulus ratio	$\rho_{Ec} = 0.5$
Long-term concrete modulus of elasticity	$E_{c,lt} = E_{c,st} \times \rho_{Ec} = 1746 \text{ ksi}$
Weight of wet concrete slab	$F_{c,wet} = (t_c + h_r/2) \times w_{c,wet} = 68.7 \text{ psf}$
Weight of dry concrete slab	$F_{c,dry} = (t_c + h_r/2) \times w_{c,dry} = 66.5 \text{ psf}$

Design Criteria

Bending safety factor – steel section	$\Omega_{b,steel} = 1.67$	AISC 360-05 F1.1
Bending safety factor – composite section	$\Omega_{b,comp} = 1.67$	AISC 360-05 I3.2a

For this example, it is assumed that the metal deck DOES NOT brace the top flange during the construction stage. Girder is braced at the locations of the supported beams at 10 ft along the girder.

Unbraced length $L_b = 10 \text{ ft}$

Calculate Lateral-torsional buckling modification factor at each critical location



CSC Inc
500 N Michigan Ave
Chicago, IL 60611

Project				Job Ref.	
ASD Girder Design Example				Design Examples	
Section				Sheet no./rev.	
Composite Beam Design				3	
Calc. by	Date	Chk'd by	Date	App'd by	Date
JRE	4/7/2009	AJR	4/8/2009	JRE	4/9/2009

Do not Camber the girder

Deflection Limits

Total Construction	$\Delta_{tot_const_max} = L_{gr}/240 = 1.50$ in
Composite stage	
Slab loads	$\Delta_{slab_comp_max} = L_{gr}/240 = 1.50$ in
Live Loads	$\Delta_{LL_comp_max} = L_{gr}/360 = 1.00$ in
Total	$\Delta_{tot_comp_max} = L_{gr}/240 = 1.50$ in

Studs

Stud Diameter	$stud_{dia} = 0.75$ in
Stud Tensile strength	$F_u = 65$ ksi
Absolute minimum composite action is 50%, Advisory minimum composite is 50%	

Beam Line Loads

Beam weight	$Weight_{BM} = 35.0$ plf
Slab and Deck	
Wet Slab	$w_{slab_wet} = (F_{c_wet} + F_{md}) \times S_{bm} = 714$ plf
Dry Slab	$w_{slab_dry} = (F_{c_dry} + F_{md}) \times S_{bm} = 691$ plf
Live	
Full	$w_{LL} = F_{LL} \times S_{bm} = 1000$ plf
Long-term	$w_{LL_lt} = F_{LL_lt} \times S_{bm} = 330$ plf
Short-term	$w_{LL_st} = F_{LL_st} \times S_{bm} = 670$ plf
Superimposed Dead Load	$w_{SDL} = F_{SDL} \times S_{bm} = 150$ plf
Construction Live Load	$w_{CCL} = F_{CCL} \times S_{bm} = 200$ plf

Girder Point Loads

Beam Dead	$P_{beam_dead} = Weight_{BM} \times L_{bm} = 1.3$ kips
Slab and Deck	
Wet Slab	$P_{slab_wet} = w_{slab_wet} \times L_{bm} = 25.0$ kips
Dry Slab	$P_{slab_dry} = w_{slab_dry} \times L_{bm} = 24.2$ kips
Live	
Full	$P_{LL} = w_{LL} \times L_{bm} = 35.0$ kips
Long-term	$P_{LL_lt} = w_{LL_lt} \times L_{bm} = 11.6$ kips
Short-term	$P_{LL_st} = w_{LL_st} \times L_{bm} = 23.5$ kips
Superimposed Dead Load	$P_{SDL} = w_{SDL} \times L_{bm} = 5.3$ kips
Construction Live Load	$P_{CCL} = w_{CCL} \times L_{bm} = 7.0$ kips

Design Loads (ASD)

Dead Load strength combination factor	$f_{DL_st} = 1.0$
Live Load strength combination factor	$f_{LL_st} = 1.0$
Construction Stage Point Load (uses wet slab weight)	$P_{r_const} = f_{DL_st} \times (P_{beam_dead} + P_{slab_wet}) + f_{LL_st} \times (P_{CCL}) = 33.3$ kips
Construction Stage Line Load	$w_{r_const} = f_{DL_st} \times (Weight_{GR}) = 68.0$ plf
Composite Stage Point Load (uses dry slab weight)	$P_{r_comp} = f_{DL_st} \times (P_{beam_dead} + P_{slab_dry} + P_{SDL}) + f_{LL_st} \times (P_{LL}) = 65.8$ kips
Composite Stage Line Load	$w_{r_comp} = f_{DL_st} \times (Weight_{GR}) = 68.0$ plf

Project ASD Girder Design Example				Job Ref. Design Examples	
Section Composite Beam Design				Sheet no./rev. 4	
Calc. by JRE	Date 4/7/2009	Chk'd by AJR	Date 4/8/2009	App'd by JRE	Date 4/9/2009

CONSTRUCTION STAGE

Construction Stage Design Checks – Shear (Girder End)

Required Shear Strength

$$V_{r, \text{const}} = P_{r, \text{const}} + w_{r, \text{const}} \times (L_{gr}/2) = \mathbf{34.3 \text{ kips}}$$

Web slenderness ratio

$$h_{to_tw} = \mathbf{52.0}$$

Compact web maximum slenderness ratio

$$h_{to_tw_max} = 2.24 \times \sqrt{(E_s/F_y)} = \mathbf{53.9}$$

$h_{to_tw} < h_{to_tw_max}$ therefore AISC 360-05 G2.1(a) and (G2-2) apply and $C_v = 1.0$

Shear safety factor – steel only

$$\Omega_{v, \text{steel}} = 1.50$$

Web area

$$A_w = \mathbf{9.84 \text{ in}^2}$$

Nominal shear strength

$$V_n = 0.6 \times F_y \times A_w \times C_v = \mathbf{295.2 \text{ kips}} \text{ (G2-1)}$$

Available shear strength

$$V_c = V_n / \Omega_{v, \text{steel}} = \mathbf{196.8 \text{ kips}}$$

$V_c > V_{r, \text{const}}$ therefore construction stage shear strength is OK

Construction Stage Design Checks – Flexure (Girder Centerline)

Required flexural strength

$$M_{r, \text{const}} = P_{r, \text{const}} \times S_{bm} + w_{r, \text{const}} \times (L_{gr}^2/8) = \mathbf{340.7 \text{ kip_ft}}$$

The W24X68 section is doubly symmetric and has compact web and flanges in flexure (see User Note AISC360-05 F2), therefore section F2 applies.

Unbraced length

$$L_b = \mathbf{10.0 \text{ ft}}$$

Radius of gyration

$$r_y = \mathbf{1.87 \text{ in}}$$

Flexural shape factor

$$c = 1$$

Moment of inertia about y-axis

$$I_y = \mathbf{70.4 \text{ in}^4}$$

Warping constant

$$C_w = \mathbf{9430 \text{ in}^6}$$

Section Modulus

$$S_x = \mathbf{154.0 \text{ in}^3}$$

Effective radius of gyration

$$r_{ts} = \sqrt{\frac{\sqrt{I_y C_w}}{S_x}}$$

$$r_{ts} = \mathbf{2.30 \text{ in}}$$

Torsional constant

$$J = \mathbf{1.87 \text{ in}^4}$$

Steel Girder depth

$$d_s = \mathbf{23.70 \text{ in}}$$

Steel Girder flange thickness

$$t_f = \mathbf{0.59 \text{ in}}$$

Distance between flange centroids

$$h_o = d_s - t_f = \mathbf{23.12 \text{ in}}$$

Limiting unbraced length for yielding

$$L_p = 1.76 r_y \sqrt{\frac{E_s}{F_y}}$$

$$L_p = \mathbf{6.61 \text{ ft}}$$

Limiting unbraced length for inelastic lateral-torsional buckling

$$L_r = 1.95 r_{ts} \frac{E_s}{.7 F_y} \sqrt{\frac{Jc}{S_x h_o}} \sqrt{1 + \sqrt{1 + 6.76 \left(\frac{.7 F_y S_x h_o}{E_s Jc} \right)}}$$

$$L_r = \mathbf{18.86 \text{ ft}}$$

The unbraced length, L_b , is greater than L_p and less than L_r , therefore the limit states of Yielding and Lateral-Torsional Buckling (LTB) apply (AISC 360-05 F2.2) and the nominal flexural strength is determined by (F2-2)

Project ASD Girder Design Example				Job Ref. Design Examples	
Section Composite Beam Design				Sheet no./rev. 5	
Calc. by JRE	Date 4/7/2009	Chk'd by AJR	Date 4/8/2009	App'd by JRE	Date 4/9/2009

LTB modification factor

$$M_{max} = M_{r,const} = 340.7 \text{ kip_ft}$$

At quarter point $l_A = 12.5 \text{ ft}$

$$M_A = P_{r,const} \times S_{bm} + w_{r,const} \times l_A / 2 \times (L_{gr} - l_A) = 340.4 \text{ kip_ft}$$

At centerline

$$M_B = M_{r,const} = 340.7 \text{ kip_ft}$$

At three-quarter point $l_C = 17.5 \text{ ft}$

$$M_C = P_{r,const} \times S_{bm} + w_{r,const} \times l_C / 2 \times (L_{gr} - l_C) = 340.4 \text{ kip_ft}$$

Cross-section monosymmetry parameter

$R_m = 1.0$ doubly symmetric member

Lateral-torsional buckling modification factor

$$C_b = \frac{12.5M_{max}}{2.5M_{max} + 3M_A + 4M_B + 3M_C} R_m$$

$$C_b = 1.00$$

Plastic Section Modulus

$$Z_x = 177.0 \text{ in}^3$$

Plastic Flexural Strength

$$M_p = F_y \times Z_x = 737.5 \text{ kip_ft (F2-1)}$$

Nominal Flexural Strength per (F2-2)

$$M_{n,F2,2} = C_b \left[M_p - (M_p - 0.7F_y S_x) \left(\frac{L_b - L_p}{L_r - L_p} \right) \right]$$

$$M_{n,F2,2} = 657.8 \text{ kip_ft}$$

Nominal Flexural Strength

$$M_{n,const} = \text{Min}(M_p, M_{n,F2,2}) = 657.8 \text{ kip_ft}$$

Available Flexural Strength

$$M_{c,const} = M_{n,const} / \Omega_{b,steel} = 393.9 \text{ kip_ft}$$

$M_{c,const} > M_{r,const}$ therefore construction stage flexural strength is OK

The unbraced lengths from the girder ends to the location of the supported beams (10 ft from girder end) need also be checked. However, the unbraced length is 10 ft and C_b will be greater than one due to the non-uniform moment in these regions. Therefore the available strength will be greater than or equal to that calculated for the center region. The required flexural strength will be essentially the same as at the centerline. Therefore the end regions are OK for the construction stage flexure as well. The details of the calculation are not shown.

Construction Stage Design Checks – Deflection (Beam Centerline)

Moment of Inertia of bare steel beam

$$I_x = 1830.0 \text{ in}^4$$

Dead Load deflection - due to girder self weight, supported beam weight and slab wet (includes metal deck weight)

$$\Delta_{DL,const} = 5 \times (\text{Weight}_{GR}) \times L_{gr}^4 / (384 \times E_s \times I_x) + (P_{slab,wet} + P_{beam,dead}) \times L_{gr}^3 / (28 \times E_s \times I_x) = 0.85 \text{ in}$$

Camber = 0 in

Construction Live load deflection

$$\Delta_{LL,const} = P_{CLL} \times L_{gr}^3 / (28 \times E_s \times I_x) = 0.22 \text{ in}$$

Total construction stage deflection

$$\Delta_{tot,const} = (\Delta_{DL,const} - \text{Camber}) + \Delta_{LL,const} = 1.07 \text{ in}$$

Construction Stage Deflection Limit

$$\Delta_{tot,const,max} = 1.50 \text{ in}$$

$\Delta_{tot,const} > \Delta_{tot,const,max}$ therefore construction stage deflection OK

COMPOSITE STAGE

Composite Stage Design Checks – Shear (Girder End)

Required Shear Strength

$$V_{r,comp} = P_{r,comp} + w_{r,comp} \times (L_{gr}/2) = 66.8 \text{ kips}$$

Shear strength for composite section is based on the bare steel beam only (AISC 360-05 13.1b), therefore Chapter G applies and the nominal and available shear strengths are the same as those for the construction stage.

Nominal shear strength

$$V_n = 295.2 \text{ kips (G2-1)}$$

Available shear strength

$$V_c = V_n / \Omega_{v,steel} = 196.8 \text{ kips}$$

$V_c > V_{r,comp}$ therefore shear strength is OK

Project ASD Girder Design Example				Job Ref. Design Examples	
Section Composite Beam Design				Sheet no./rev. 6	
Calc. by JRE	Date 4/7/2009	Chk'd by AJR	Date 4/8/2009	App'd by JRE	Date 4/9/2009

Composite Stage Design- Flexure (General)

Web slenderness ratio	$h_{to_t_w} = 52.0$	
Web maximum slenderness ratio	$h_{to_t_w_maxcomp} = 3.76 \times \sqrt{(E_s/F_y)} = 90.6$	
<i>$h_{to_t_w} < h_{to_t_w_maxcomp}$ therefore AISC 360-05 I3.2a(a) applies and the nominal flexural strength of the composite section can be determined from the plastic stress distribution on the composite section</i>		
Effective concrete width	$b_{eff} = \text{Min}(2 \times L_{gr}/8, 2 \times S_{gr}/2) = 90.0$ in	
Effective area of concrete	$A_c = (b_{eff} \times t_c) + [h_r \times (w_{rt} + w_{rb})/2] \times (b_{eff}/s_r) = 495.0$ in ²	
<i>Concrete below top of deck is included in composite properties for parallel metal deck [AISC 360-05 I3.2c(2)]. The equation for A_c includes the area of one rib multiplied by the approximate number of ribs, (b_{eff}/s_r).</i>		
Area of steel beam	$A_s = 20.1$ in ²	
Stud strength - any number of studs per group		
Group Factor: Any number of studs welded in a row through the steel deck with the deck oriented parallel to the steel shape and the ratio of average rib width to rib depth, $w_r/h_r = 3.00$, is greater than 1.5 (AISC 360-05 I3.2d(3))		
$R_g = 1.0$		
Position Factor: Studs welded in a composite slab with the deck oriented parallel to the beam (AISC 360-05 I3.2d(3))		
$R_p = 0.75$		
Nominal Stud Strength		
Cross-sectional area of shear connector	$A_{sc} = \pi \times (\text{stud}_{dia}/2)^2 = 0.44$ in ²	
Nominal strength based on concrete	$Q_{n_conc} = 0.5 \times A_{sc} \times \sqrt{(f_c \times E_{c_st})} = 26.1$ kips	AISC 360-05 (I3-3)
Nominal strength based on geometry	$Q_{n_geom} = R_g \times R_p \times A_{sc} \times F_u = 21.5$ kips	AISC 360-05 (I3-3)
Nominal strength of one stud	$Q_n = \text{Min}(Q_{n_conc}, Q_{n_geom}) = 21.5$ kips	
Minimum longitudinal stud spacing	$S_{st_min} = 6 \times \text{stud}_{dia} = 4.50$ in	
Maximum longitudinal stud spacing	$S_{st_max} = \text{Min}(8 \times [t_c + h_r], 36 \text{ in}) = 36.00$ in	
Minimum transverse stud spacing	$S_{st_trans_min} = 4 \times \text{stud}_{dia} = 3.00$ in	
Girder flange width	$b_f = 8.97$ in	
Minimum flange width assuming 1.5 in edge distance	$b_{f_min} = S_{st_trans_min} + 2 \times 1.5 \text{ in} = 6.0$ in	
<i>$b_f > b_{f_min}$ therefore two studs per row OK</i>		
Horizontal shear at beam-slab interface		
Shear - Concrete Crushing	$V_{p_concrete_crushing} = 0.85 \times f_c \times A_c = 1683.0$ kips	
Shear - Steel Yielding	$V_{p_steel_yield} = F_y \times A_s = 1005.0$ kips	
Shear at full interaction	$V_{p_Full} = \text{Min}(V_{p_concrete_crushing}, V_{p_steel_yield}) = 1005.0$ kips	

Composite Section Properties

The steel section is idealized as a series of three rectangles. The total area of the steel section is maintained by incorporating the area of the fillet radius into the flanges. This is accomplished by increasing the width of the top and bottom flange.

Steel girder depth	$d_s = 23.70$ in
Steel girder web thickness	$t_w = 0.41$ in
Steel girder flange thickness	$t_f = 0.59$ in
Area of steel girder web	$A_{web} = (d_s - 2 \times t_f) \times t_w = 9.35$ in ²
Steel girder flange width	$b_f = 8.97$ in

Project				Job Ref.	
ASD Girder Design Example				Design Examples	
Section				Sheet no./rev.	
Composite Beam Design				7	
Calc. by	Date	Chk'd by	Date	App'd by	Date
JRE	4/7/2009	AJR	4/8/2009	JRE	4/9/2009

Effective area of each flange for use in composite section calculations

$$A_{f,eff} = (A_s - A_{web})/2 = 5.38 \text{ in}^2$$

Effective width of flanges for use in composite section calculations

$$b_{f,eff} = A_{f,eff}/t_f = 9.19 \text{ in}$$

Tensile Strength of steel

$$P_y = V_{p,steel,yield} = 1005.0 \text{ kips}$$

Max compression force in steel flange

$$C_{steel,flange,max} = F_y \times t_f \times b_{f,eff} = 268.8 \text{ kips}$$

Composite Stage Design Checks – Flexure (@ Point Loads)

Distance from Girder End to Critical Location $d_{crit,PL} = 10 \text{ ft}$

Required flexural strength $M_{r,comp,PL} = P_{r,comp} \times d_{crit,PL} + w_{r,comp} \times d_{crit,PL}/2 \times (L_{gr} - d_{crit,PL}) = 664.8 \text{ kip_ft}$

Number of Studs from beam end to 10 ft from girder end, two studs per row $N_{studs,PL} = 24$

Stud spacing $S_{st,PL} = d_{crit,PL}/(N_{studs,PL}/2) = 10.00 \text{ in}$

$S_{st,max} > S_{st,PL} > S_{st,min}$ therefore stud spacing OK

Horizontal shear at beam-slab interface

Shear in Studs

$$V_{p,studs,PL} = N_{studs,PL} \times Q_n = 516.9 \text{ kips}$$

Horizontal shear

$$V_{p,PL} = \text{Min}(V_{p,studs,PL}, V_{p,concrete,crushing}, V_{p,steel,yield}) = 516.9 \text{ kips}$$

Percent composite action

$$\text{Comp}_{percent,PL} = V_{p,PL}/V_{p,Full} = 51.4 \%$$

Comp_{percent,PL} is greater than the absolute minimum (50%) – OK

Comp_{percent,PL} is less than the advisory minimum (50%) – OK

Composite Section Properties (@ Point Loads)

Compression force in concrete $C_{conc,PL} = V_{p,PL} = 516.9 \text{ kips}$

Effective depth of concrete in compression $a_{eff,PL} = C_{conc,PL}/(0.85 \times f_c \times b_{eff}) = 1.69 \text{ in}$

The effective depth is less than the concrete topping, therefore there is no contribution from the ribs and the equation above is valid. In addition, the equations for $d_{1,PL}$ and $d_{1,CL}$ can neglect the rib contribution.

Compression in Steel beam $C_{steel,PL} = (P_y - C_{conc,PL})/2 = 244.1 \text{ kips}$

Max compression force in steel flange $C_{steel,flange,max} = 268.8 \text{ kips}$

$C_{steel,PL} < C_{steel,flange,max}$ therefore plastic neutral axis is in the beam flange and $C_{steel,flange,PL} = C_{steel,PL}$

Compression force in the beam web $C_{steel,web,PL} = 0 \text{ kips}$

Distance (down) of location of plastic neutral axis from top of steel beam

$$PNA_{PL} = C_{steel,flange,PL}/(b_{f,eff} \times F_y) = 0.53 \text{ in}$$

Nominal Moment Strength is determined using Figure C-13.1 (shown below) and Equation(C-13-5) from the Commentary to AISC LRFD Specification for Structural Steel Buildings 1999. See Figure 1.

Project ASD Girder Design Example				Job Ref. Design Examples	
Section Composite Beam Design				Sheet no./rev. 8	
Calc. by JRE	Date 4/7/2009	Chk'd by AJR	Date 4/8/2009	App'd by JRE	Date 4/9/2009

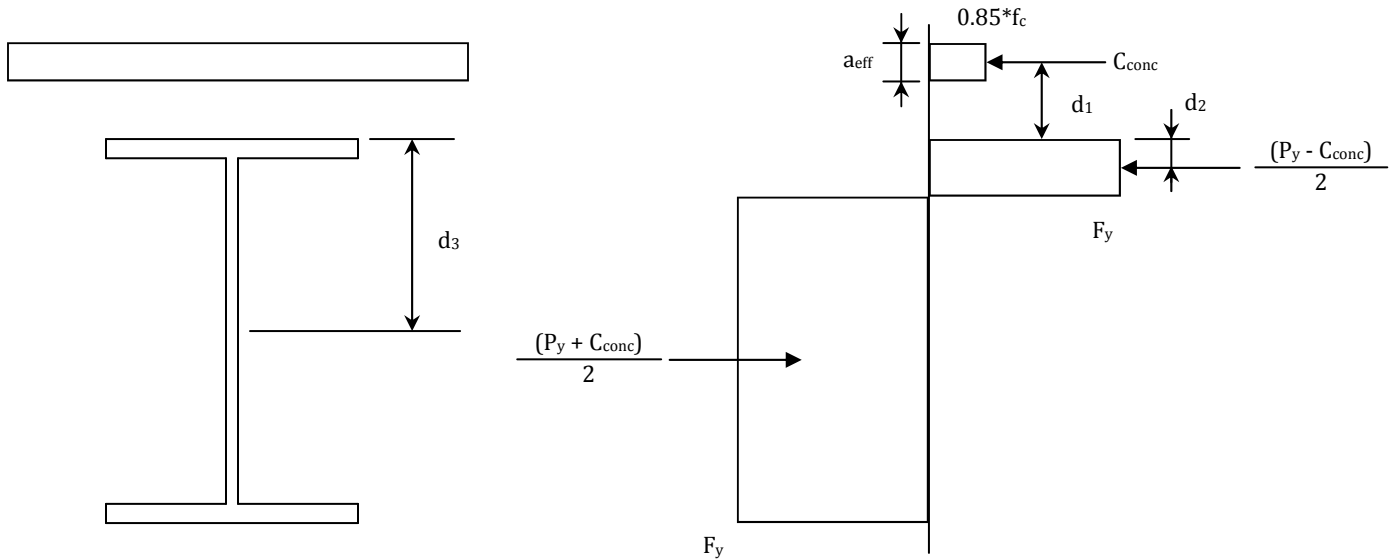

Figure 1: Commentary to the AISC LRFD Specification for Structural Steel Buildings 1999—Fig. C-13.1: Plastic Stress distribution for positive moment in composite beams.

Distance from the centroid of the compression force in the concrete to the top of the steel section

$$d_{1_PL} = (h_r + t_c) - a_{eff_PL}/2 = \mathbf{5.66 \text{ in}}$$

Distance from the centroid of the compression force in the steel section to the top of the steel section

$$d_{2_PL} = (C_{steel_flange_PL} \times PNA_{PL}/2) / C_{steel_PL} = \mathbf{0.27 \text{ in}}$$

Distance from the centroid of the steel section (and P_y) to the top of the steel section

$$d_{3_PL} = d_s/2 = \mathbf{11.85 \text{ in}}$$

Nominal Composite Flexural Strength

$$M_{n_comp_PL} = C_{conc_PL} \times (d_{1_PL} + d_{2_PL}) + P_y \times (d_{3_PL} - d_{2_PL}) = \mathbf{1225.2 \text{ kip_ft}}$$

Available Composite Flexural Strength

$$M_{c_comp_PL} = M_{n_comp_PL} / \Omega_{b_comp} = \mathbf{733.7 \text{ kip_ft}}$$

$M_{c_comp_PL} > M_{r_comp_PL}$ therefore shear strength is OK

The same design checks apply at 20 ft from the left end of the girder (the location of the other supported beams) and are not repeated.

Composite Stage Design Checks – Flexure (Girder Centerline)

Distance from Girder End to Critical Location

$$d_{crit_CL} = L_{gr}/2 = \mathbf{15.00 \text{ ft}}$$

Required flexural strength

$$M_{r_comp_CL} = P_{r_comp} \times d_{crit_PL} + W_{r_comp} \times (L_{gr}^2/8) = \mathbf{665.7 \text{ kip_ft}}$$

Number of Studs from girder end to centerline,

$$N_{studs_CL} = \mathbf{26}$$

24 (two studs per row) from girder end to 10 ft from girder end and 2 from 10 ft from girder end to girder centerline

Stud spacing, center region

$$S_{st_CL} = (d_{crit_CL} - d_{crit_PL}) / (N_{studs_CL} - N_{studs_PL}) = \mathbf{30.00 \text{ in}}$$

$S_{st_max} > S_{st_CL} > S_{st_min}$ therefore stud spacing OK

Horizontal shear at beam-slab interface

Shear in Studs

$$V_{p_studs_CL} = N_{studs_CL} \times Q_n = \mathbf{560.0 \text{ kips}}$$

Horizontal shear

$$V_{p_CL} = \text{Min}(V_{p_studs_CL}, V_{p_concrete_crushing}, V_{p_steel_yield}) = \mathbf{560.0 \text{ kips}}$$

Percent composite action

$$Comp_{percent_CL} = V_{p_CL} / V_{p_Full} = \mathbf{55.7 \%}$$

$Comp_{percent_CL}$ is greater than the absolute minimum (50%) – OK

$Comp_{percent_CL}$ is less than the advisory minimum (50%) – OK

Project ASD Girder Design Example				Job Ref. Design Examples	
Section Composite Beam Design				Sheet no./rev. 9	
Calc. by JRE	Date 4/7/2009	Chk'd by AJR	Date 4/8/2009	App'd by JRE	Date 4/9/2009

Composite Section Properties (Girder Centerline)

Compression force in concrete $C_{conc_CL} = V_{p_CL} = \mathbf{560.0}$ kips
 Effective depth of concrete in compression $a_{eff_CL} = C_{conc_CL} / (0.85 \times f_c \times b_{eff}) = \mathbf{1.83}$ in
 Compression in Steel beam $C_{steel_CL} = (P_y - C_{conc_CL}) / 2 = \mathbf{222.5}$ kips
 Max compression force in steel flange $C_{steel_flange_max} = \mathbf{268.8}$ kips
 $C_{steel_CL} < C_{steel_flange_max}$ therefore plastic neutral axis is in the beam flange and $C_{steel_flange_CL} = C_{steel_CL}$
 Compression force in the beam web $C_{steel_web_CL} = 0$ kips
 Distance (down) of location of plastic neutral axis from top of steel beam
 $PNA_{CL} = C_{steel_flange_CL} / (b_{r_eff} \times F_y) = \mathbf{0.48}$ in

Nominal Moment Strength is determined using Figure C-13.1 (shown below) and Equation(C-13-5) from the Commentary to AISC LRFD Specification for Structural Steel Buildings 1999. See Figure 1

Distance from the centroid of the compression force in the concrete to the top of the steel section

$$d_{1_CL} = (h_r + t_c) - a_{eff_CL} / 2 = \mathbf{5.59}$$
 in

Distance from the centroid of the compression force in the steel section to the top of the steel section

$$d_{2_CL} = (C_{steel_flange_CL} \times PNA_{CL} / 2) / C_{steel_CL} = \mathbf{0.24}$$
 in

Distance from the centroid of the steel section (and P_y) to the top of the steel section

$$d_{3_CL} = d_s / 2 = \mathbf{11.85}$$
 in

Nominal Composite Flexural Strength $M_{n_comp_CL} = C_{conc_CL} \times (d_{1_CL} + d_{2_CL}) + P_y \times (d_{3_CL} - d_{2_CL}) = \mathbf{1244.1}$ kip_ft

Available Composite Flexural Strength $M_{c_comp_CL} = M_{n_comp_CL} / \Omega_{b_comp} = \mathbf{745.0}$ kip_ft

$M_{c_comp_CL} > M_{r_comp_CL}$ therefore shear strength is OK

Composite Stage Design Checks – Elastic Section Properties (Girder Centerline)

Steel Girder Moment of Inertia $I_x = \mathbf{1830.0}$ in⁴
 Steel Girder Area $A_s = \mathbf{20.10}$ in²
 Area of Concrete $A_c = \mathbf{495.0}$ in²

The concrete is treated as a solid rectangle above the deck and as a series of trapezoids within the deck ribs. The properties of one trapezoid are then multiplied by the effective number of trapezoids within the effective width, b_{eff}/s_r . See Figure 2.

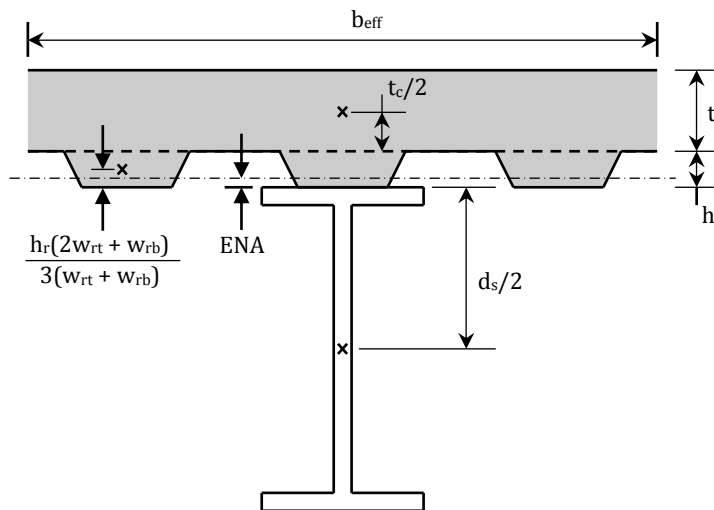

Figure 2: Elastic Composite Section

Project ASD Girder Design Example				Job Ref. Design Examples	
Section Composite Beam Design				Sheet no./rev. 10	
Calc. by JRE	Date 4/7/2009	Chk'd by AJR	Date 4/8/2009	App'd by JRE	Date 4/9/2009

Depth from bottom of concrete to centroid of concrete

$$d_c = \frac{(b_{eff} \times t_c) \times (h_r + t_c/2) + \left(\frac{h_r(w_{rt} + w_{rb})}{2} \times \frac{h_r(2w_{rt} + w_{rb})}{3(w_{rt} + w_{rb})} \right) \times \frac{b_{eff}}{s_r}}{A_c}$$

$$d_c = 3.67 \text{ in}$$

Moment of inertia of the concrete about its centroid

$$I_c = \frac{b_{eff} t_c^3}{12} + (b_{eff} t_c) [h_r + t_c/2 - d_c]^2 + \left\{ \frac{h_r^3 (w_{rt}^2 + 4w_{rt}w_{rb} + w_{rb}^2)}{36(w_{rt} + w_{rb})} + \left(\frac{h_r(w_{rt} + w_{rb})}{2} \right) \left[d_c - \frac{h_r(2w_{rt} + w_{rb})}{3(w_{rt} + w_{rb})} \right]^2 \right\} \times \left(\frac{b_{eff}}{s_r} \right)$$

$$I_c = 1465 \text{ in}^4$$

Short-term modular ratio

$$n_{st} = E_s/E_{c,st} = 8.3$$

Short-term Elastic neutral axis (up from top of steel beam)

$$ENA_{st} = \frac{A_c/n_{st} \times d_c - A_s \times d_s/2}{A_c/n_{st} + A_s}$$

$$ENA_{st} = -0.24 \text{ in}$$

Short-term transform moment of inertia taken about the elastic neutral axis

$$I_{tr,st} = I_x + A_s \left(\frac{d_s}{2} + ENA_{st} \right)^2 + I_c/n_{st} + \left(A_c/n_{st} \right) [d_c - ENA_{st}]^2$$

$$I_{tr,st} = 5627 \text{ in}^4$$

Short-term transform moment of inertia with correction for deviation from elastic theory AISC 360-05 Commentary C-13.1

$$I_{tr,eff,st} = 0.75 \times I_{tr,st} = 4220 \text{ in}^4$$

Short-term effective moment of inertia due to partial composite action AISC 360-05 Commentary (C-13-3), $V_{p,CL}$ at centerline

$$I_{eff,st} = I_x + (I_{tr,eff,st} - I_x) \sqrt{V_{p,CL}/V_{p,Full}}$$

$$I_{eff,st} = 3614 \text{ in}^4$$

Long-term modular ratio

$$n_{lt} = E_s/E_{c,lt} = 16.6$$

Long-term Elastic neutral axis (up from top of steel beam)

$$ENA_{lt} = \frac{A_c/n_{lt} \times d_c - A_s \times d_s/2}{A_c/n_{lt} + A_s}$$

$$ENA_{lt} = -2.58 \text{ in}$$

Long-term transform moment of inertia taken about elastic neutral axis

$$I_{tr,lt} = I_x + A_s \left(\frac{d_s}{2} + ENA_{lt} \right)^2 + I_c/n_{lt} + \left(A_c/n_{lt} \right) [d_c - ENA_{lt}]^2$$

$$I_{tr,lt} = 4809 \text{ in}^4$$

Long-term transform moment of inertia with correction for deviation from elastic theory AISC 360-05 Commentary C-13.1

$$I_{tr,eff,lt} = 0.75 \times I_{tr,lt} = 3607 \text{ in}^4$$

Long-term effective moment of inertia due to partial composite action AISC 360-05 Commentary (C-13-3), $V_{p,CL}$ at centerline

$$I_{eff,lt} = I_x + (I_{tr,eff,lt} - I_x) \sqrt{V_{p,CL}/V_{p,Full}}$$

$$I_{eff,lt} = 3156 \text{ in}^4$$

Composite Stage Design Checks - Deflections

Camber = 0.00 in

Slab loads (Beam weight and dry slab weight, including metal deck and camber) on steel beam

Girder weight (self weight)

$$\Delta_{Girder} = 5 \times (\text{Weight}_{GR}) \times L_{gr}^4 / (384 \times E_s \times I_x) = 0.02 \text{ in}$$

Beam Dead

$$\Delta_{beam_dead} = (P_{beam_dead}) \times L_{gr}^3 / (28 \times E_s \times I_x) = 0.04 \text{ in}$$

Dry slab weight only

$$\Delta_{slab_only} = (P_{slab_dry}) \times L_{gr}^3 / (28 \times E_s \times I_x) = 0.76 \text{ in}$$

Project ASD Girder Design Example				Job Ref. Design Examples	
Section Composite Beam Design				Sheet no./rev. 11	
Calc. by JRE	Date 4/7/2009	Chk'd by AJR	Date 4/8/2009	App'd by JRE	Date 4/9/2009

Total Slab $\Delta_{slab_total} = \Delta_{Girder} + \Delta_{beam_dead} + \Delta_{slab_only} = \mathbf{0.82}$ in
Slab Adjusted for Camber $\Delta_{slab} = \Delta_{slab_total} - \text{Camber} = \mathbf{0.82}$ in
 Slab Deflection Limit $\Delta_{slab_comp_max} = \mathbf{1.50}$ in
 $\Delta_{slab_comp_max} > \Delta_{slab}$ **therefore slab load deflection is OK**

Live Loads (take into account long- and short-term concrete moduli and loads) on composite section
 Short-term live load deflection $\Delta_{LL_st} = (P_{LL_st}) \times L_{gr}^3 / (28 \times E_s \times I_{eff_st}) = \mathbf{0.37}$ in
 Long-term live load deflection $\Delta_{LL_lt} = (P_{LL_lt}) \times L_{gr}^3 / (28 \times E_s \times I_{eff_lt}) = \mathbf{0.21}$ in
Total live load deflection $\Delta_{LL} = \Delta_{LL_st} + \Delta_{LL_lt} = \mathbf{0.58}$ in
 Live Load Deflection Limit $\Delta_{LL_comp_max} = \mathbf{1.00}$ in
 $\Delta_{LL_comp_max} > \Delta_{LL}$ **therefore live load deflection is OK**

Dead Load (all load considered long-term) on composite section
Superimposed Dead $\Delta_{SDL} = (P_{SDL}) \times L_{gr}^3 / (28 \times E_s \times I_{eff_lt}) = \mathbf{0.10}$ in
 Total Deflection
Total Deflection (incl. Camber) $\Delta_{tot_comp} = \Delta_{slab} + \Delta_{LL} + \Delta_{SDL} = \mathbf{1.50}$ in
 Total Deflection Limit $\Delta_{tot_comp_max} = \mathbf{1.50}$ in
 $\Delta_{tot_comp_max} \geq \Delta_{tot_comp}$ **therefore total deflection is OK**

In these calculations for deflection, the weight of the supported beams is applied to the bare steel girder. In the sample file provided with FASTRAK Composite Beam Design a slightly different approach is taken. The beam weight is added as a standard dead load case and the deflection due to this load is applied to the composite section as a long-term load. This results in a small difference in the deflections (as shown below) from the calculations included above. The loads were added as a separate load case to simplify the load input and to clearly indicate that the supported steel weight was included. To include the beam weight as it is in these calculations, it can be added to the 'slab wet' and 'slab dry' load cases instead of its own additional dead load case. The following deflections correspond to the manner in which the loads were added in FASTRAK Composite Beam Design (FCBD).

Girder weight (self weight) $\Delta_{Girder} = 5 \times (\text{Weight}_{GR}) \times L_{gr}^4 / (384 \times E_s \times I_x) = \mathbf{0.02}$ in
 Total Slab (not including steel weight) $\Delta_{slab_total_FCBD} = \Delta_{slab_only} = \mathbf{0.76}$ in
 Slab Adjusted for Camber $\Delta_{slab_FCBD} = \Delta_{slab_total_FCBD} - \text{Camber} = \mathbf{0.76}$ in
 Beam Dead – applied to composite section $\Delta_{beam_dead_FCBD} = (P_{beam_dead}) \times L_{gr}^3 / (28 \times E_s \times I_{eff_lt}) = \mathbf{0.02}$ in
 Superimposed Dead (Dead) $\Delta_{SDL} = \mathbf{0.10}$ in
 Total Dead load on composite section $\Delta_{dead_comp_FCBD} = \Delta_{beam_dead_FCBD} + \Delta_{SDL} = \mathbf{0.12}$ in
 Total live load deflection $\Delta_{LL} = \mathbf{0.58}$ in
Total deflection $\Delta_{tot_comp_FCBD} = \Delta_{slab_FCBD} + \Delta_{LL} + \Delta_{Girder} + \Delta_{dead_comp_FCBD} = \mathbf{1.49}$ in

Note: If you are working with FASTRAK Building Designer to establish and compare these beam examples, all the steel weight is automatically included in the 'self weight' load case and is applied to the bare steel girder as indicated in these calculations. All the geometry, flange bracing, floor construction, and loading data is generated by FASTRAK Building Designer within the full building model and can be automatically exported to the composite beam design component for more detailed analysis.



CSC Inc
500 N Michigan Ave
Chicago, IL 60611

Project ASD Girder Design Example				Job Ref. Design Examples	
Section Composite Beam Design				Sheet no./rev. 12	
Calc. by JRE	Date 4/7/2009	Chk'd by AJR	Date 4/8/2009	App'd by JRE	Date 4/9/2009

SUMMARY – W24X68 (24, 4, 24)

Construction Stage

<i>Design Condition</i>	<i>Critical Value</i>	<i>Capacity Limit</i>	<i>Ratio</i>
Vertical Shear (End)	$V_{r_const} = 34$ kips	$V_c = 197$ kips	$V_{r_const} / V_c = 0.174$
Flexure (Centerline)	$M_{r_const} = 341$ kip_ft	$M_{c_const} = 394$ kip_ft	$M_{r_const} / M_{c_const} = 0.865$
Deflection (Centerline)	$\Delta_{tot_const} = 1.07$ in	$\Delta_{tot_const_max} = 1.50$ in	$\Delta_{tot_const} / \Delta_{tot_const_max} = 0.713$

Composite Stage

<i>Design Condition</i>	<i>Critical Value</i>	<i>Capacity Limit</i>	<i>Ratio</i>
Vertical Shear (End)	$V_{r_comp} = 67$ kips	$V_c = 197$ kips	$V_{r_comp} / V_c = 0.340$
Flexure (Point Loads)	$M_{r_comp_PL} = 665$ kip_ft	$M_{c_comp_PL} = 734$ kip_ft	$M_{r_comp_PL} / M_{c_comp_PL} = 0.906$
Flexure (Centerline)	$M_{r_comp_CL} = 666$ kip_ft	$M_{c_comp_CL} = 745$ kip_ft	$M_{r_comp_CL} / M_{c_comp_CL} = 0.894$
Deflections	Camber = 0.00 in		
Slab (incl. Camber)	$\Delta_{slab} = 0.82$ in	$\Delta_{slab_comp_max} = 1.50$ in	$\Delta_{slab} / \Delta_{slab_comp_max} = 0.549$
Live	$\Delta_{LL} = 0.58$ in	$\Delta_{LL_comp_max} = 1.00$ in	$\Delta_{LL} / \Delta_{LL_comp_max} = 0.583$
Superimposed Dead	$\Delta_{SDL} = 0.10$ in	NA	
Total	$\Delta_{tot_comp} = 1.50$ in	$\Delta_{tot_comp_max} = 1.50$ in	$\Delta_{tot_comp} / \Delta_{tot_comp_max} = 1.000$

DESIGN METHOD:

There is a direct relationship between the safety factors (Ω) used in ASD and the resistance factors (ϕ) used for LRFD. Namely, $\Omega=1.5/\phi$. When the required strength using LRFD load combinations is about 1.5 times the strength required using ASD load combinations, the design of the two methods will likely be the same. This corresponds to a live load to dead load ratio of 3 for load combinations involving only live and dead loads. When the ratio is less than 3 the ASD method may require larger steel sections or more studs. When the ratio is greater than 3 the LRFD method may require larger steel sections or more studs.

In this example, the composite live to dead load ratio is: $(P_{LL}) / (P_{SDL} + P_{slab_dry} + P_{beam_dead} + Weight_{GR} \times L_{gr}) = 1.07$

This means there is the potential that the ASD method will require a heavier steel section or more studs. However, the overall design for this example girder using the LRFD method of design is the same as when the ASD method is used. This is due to the fact that the number of studs is based on achieving the minimum required composite action of 50% and the fact that the deflection controls the design. The details of the LRFD design are presented in the design example entitled "LRFD Girder" – available on the online support website: http://www.cscworld.com/fastrak/us/composite_resources.html.